

Total solder points: 148

Difficulty level: *beginner* 1 2 3 4 5 *advanced*

ELECTRONIC RECORD/PLAYBACK MODULE

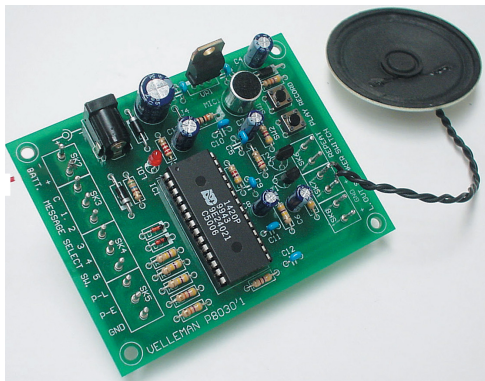

K8030

High-quality, natural voice/
audio reproduction.

Features:

- ☑ High-quality, natural voice/audio reproduction.
- ☑ Can be used to greet visitors, play pranks, warn burglars,...
- ☑ EEPROM technology with 100-year message retention.
- ☑ Microphone included.
- ☑ From 4 to 20 seconds of recording time per module.
- ☑ No memory loss in case of power failure.
- ☑ Loudspeaker included.
- ☑ 2 Play modes:
 - Push once to play message.
 - Play message until button is released.
- ☑ Add an optional rotary switch (8404-1C) for message selection.

Specifications:

- 8 ~ 16 Ohm, 120 mW speaker output.
- Power supply: 8 – 18 VDC, or 6V battery.
- Power consumption:
 - DC power supply: 4mA in standby, max 100mA when playback.
 - Battery operated :20µA in standby, max 100mA when playback.
- Sampling frequency: 6.4KHz.
- Dimensions: 94 x 73 x 25 mm / 3.7" x 2.9" x 1"

1. Assembly (Skipping this can lead to troubles !)

Ok, so we have your attention. These hints will help you to make this project successful. Read them carefully.

1.1 Make sure you have the right tools:

- A good quality soldering iron (25-40W) with a small tip.
- Wipe it often on a wet sponge or cloth, to keep it clean; then apply solder to the tip, to give it a wet look. This is called 'thinning' and will protect the tip, and enables you to make good connections. When solder rolls off the tip, it needs cleaning.
- Thin raisin-core solder. Do not use any flux or grease.
- A diagonal cutter to trim excess wires. To avoid injury when cutting excess leads, hold the lead so they cannot fly towards the eyes.
- Needle nose pliers, for bending leads, or to hold components in place.
- Small blade and Phillips screwdrivers. A basic range is fine.

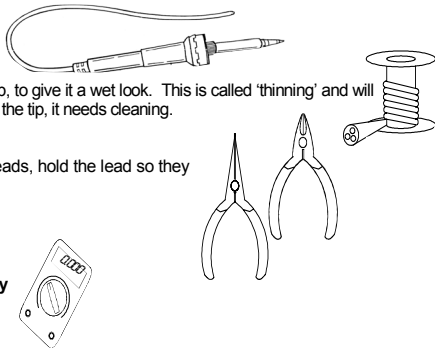

For some projects, a basic multi-meter is required, or might be handy

1.2 Assembly Hints :

- ⇒ Make sure the skill level matches your experience, to avoid disappointments.
- ⇒ Follow the instructions carefully. Read and understand the entire step before you perform each operation.
- ⇒ Perform the assembly in the correct order as stated in this manual
- ⇒ Position all parts on the PCB (Printed Circuit Board) as shown on the drawings.
- ⇒ Values on the circuit diagram are subject to changes.
- ⇒ Values in this assembly guide are correct*
- ⇒ Use the check-boxes to mark your progress.
- ⇒ Please read the included information on safety and customer service

* Typographical inaccuracies excluded. Always look for possible last minute manual updates, indicated as 'NOTE' on a separate leaflet.

1.3 Soldering Hints :

1- Mount the component against the PCB surface and carefully solder the leads

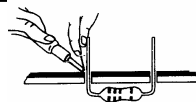

2- Make sure the solder joints are cone-shaped and shiny

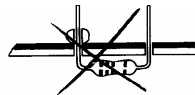
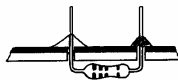

3- Trim excess leads as close as possible to the solder joint

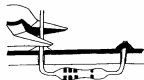

REMOVE THEM FROM THE TAPE ONE AT A TIME !

AXIAL COMPONENTS ARE TAPED IN THE CORRECT MOUNTING SEQUENCE !

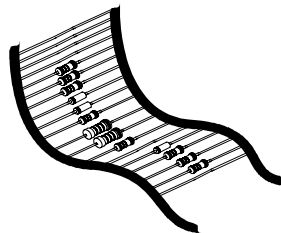

1. Jumpers

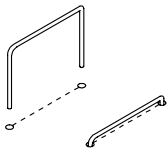

- J1
- J2
- J3
- J4

2. Diodes, check the polarity !

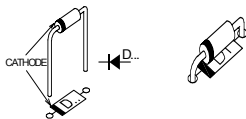

- D1 : 1N4007
- D2 : 1N4007
- D3 : 1N4007
- D4 : 1N4148
- D5 : 1N4148

3. Resistors

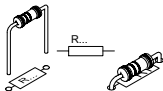

- R1 : 47K (4-7-3-B)
- R2 : 47K (4-7-3-B)
- R3 : 47K (4-7-3-B)
- R4 : 470K (4-7-4-B)
- R5 : 470K (4-7-4-B)
- R6 : 470K (4-7-4-B)
- R7 : 4K7 (4-7-2-B)
- R8 : 470K (4-7-4-B)
- R9 : 2K2 (2-2-2-B)
- R10 : 10K (1-0-3-B)
- R11 : 4K7 (4-7-2-B)
- R12 : 560 (5-6-1-B)
- R13 : 4K7 (4-7-2-B)
- R14 : 220K (2-2-4-B)
- R15 : 4K7 (4-7-2-B)

4. IC sockets. Watch the position of the notch!

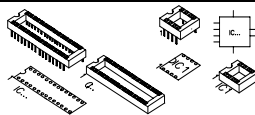

- IC1 : 28P

5. Push buttons

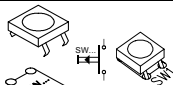

- SW1
 - SW2
- } KRS0611

6. PCB pins

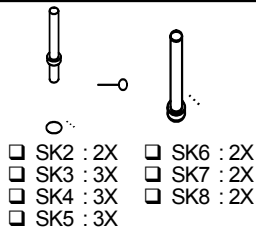

7. Ceramic Capacitors

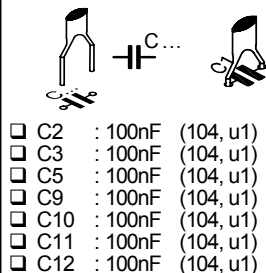
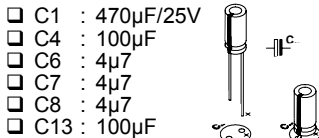
8. Electrolytic capacitor.
Watch the polarity !

9. Transistors

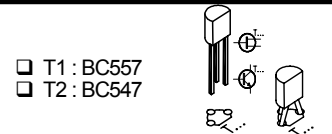

10. LED. Watch the polarity!

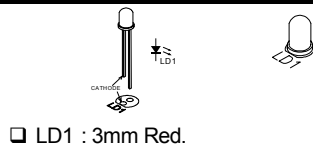

11. Voltage regulator

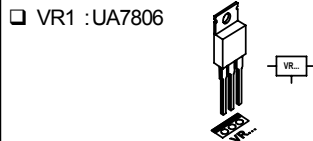

12. DC - Jack

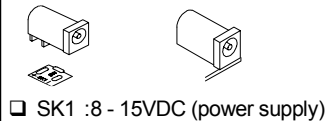

13. Microphone

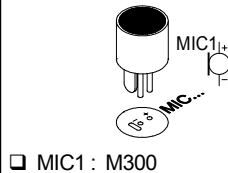

14 . IC's. Watch the position of the notch!

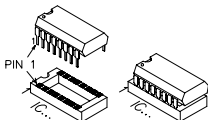

□ IC1 : ISD1420 or eq.

15. Hook-up & Use

Basic application : see section 15

Connect the included miniature speaker to the 'SPEAKER' connector SK7 using the supplied wire. If you decide to use a different speaker, get one with an impedance between 4 and 8 ohms, and a power rating of 0.25W to 2W. Higher power ratings will result in poor performance.

*Power supply :

AC powered : A connector is provided to connect a wall adaptor with an output voltage of 8 to 15VDC. Watch the polarity : the center pin is positive.

Battery powered : Six-volt battery operation (e.g. 4 x AA battery) is possible via connector SK2. Watch the polarity.

*How to record a message :

Press and hold the 'RECORD'-button. LD1 will light. The built-in microphone will capture your message. Release the 'RECORD'-button to end the recording. If LD1 turns off during recording, the memory is full and recording is stopped. Max. recording time is 20 seconds.

***How to play a message :**

Press the 'PLAY'-button once to play the message. LD1 will flash once to indicate end-of-message.

***Other features :**

- Message select : connectors SK3 and SK4 allow you to connect a selector switch (e.g. Velleman 8404-1C), which allows you to choose between 5 different messages. 'C' is common, 1 to 5 selects message. Max message length : 4 seconds (x5).
- Repeat message : short both pins of SK6 for message auto-repeat.
- External pushbuttons : Connector SK5 provides a way to connect an optional 'PLAY'-button at a remote location.
- Pushbutton between 'GND' and 'P-E' : same as the on-board play button
- Pushbutton between 'GND' and 'P-L' : same as the on-board play button, but message plays only once, regardless of the time the button is pressed.
- For best results, keep the distance between the button and the board as short as possible (2m (7') max.) and if possible, use shielded wire.

Line out : Connector SK8 provides a line out, to allow hook-up of an external amplifier e.g. our K2637 or

16. Connection & operation

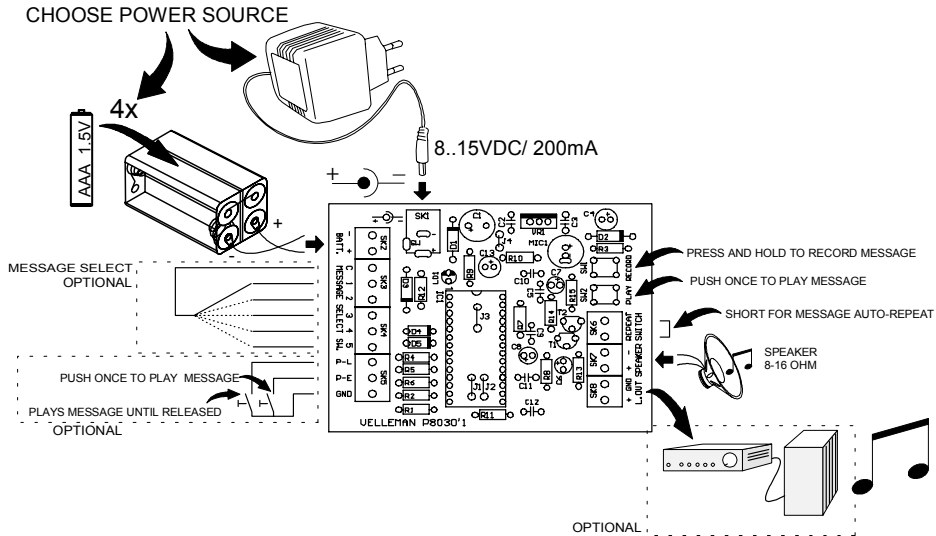

17. Schematic diagram.

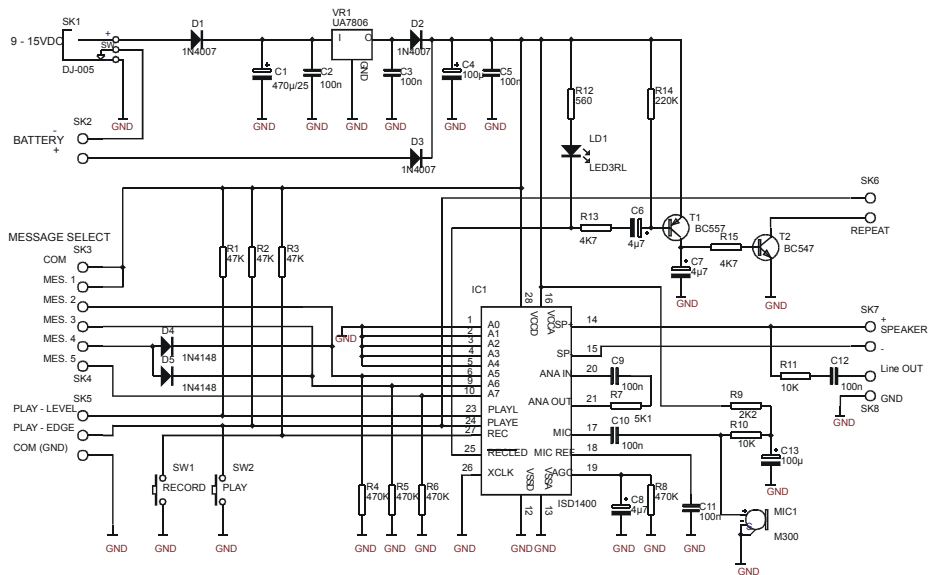

18. PCB

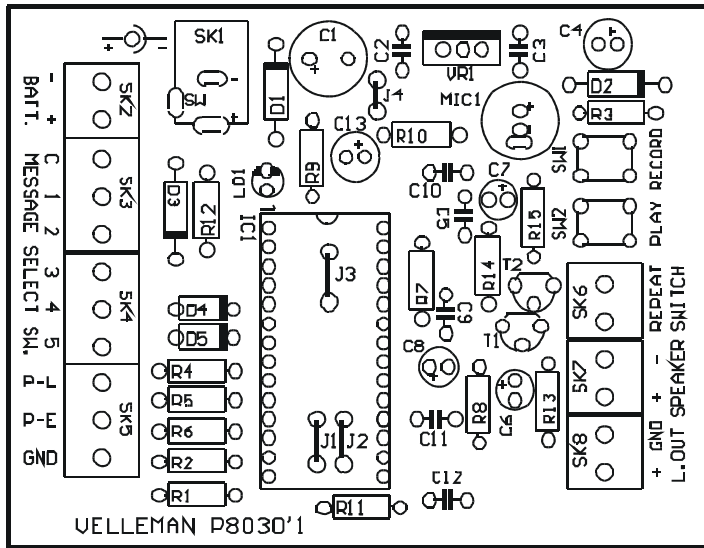



Modifications and typographical errors reserved
© Velleman Components nv.
H80301P - 2003 - ED1

