

400W MONO/STEREO AMPLIFIER

Universal, robust and compact are the words to describe this amplifier.

Total solder points: 264

Difficulty level: *beginner* 2 3 4 5 *advanced*



K4005B

Features:

- Rms output power : 2 x 100W / 4ohm ; 2 x 75W / 8ohm.
- Rms mono-bridged power : 200W / 8ohm.
- Total music output : 400W.
- Harmonic distortion : 0.003% at 1KHz.
- Signal-to-noise ratio : 96dB (A-weighted).
- Stereo channel separation : 76dB.
- Damping factor (at 100Hz) : > 2000.

Specifications:

- Input impedance : 22kohm .
- Input sensitivity : 150mV, 300mV or 950mV switchable .
- Supply voltage for 8 ohm : + 35 to 40VDC and - 35 to 40VDC / 2.5A.
- Supply voltage for 4 ohm or mono: + 25 to 30VDC and - 25 to 30VDC/ 5A
- Dimensions : 350 x 62 x 85mm (13.8" x 2.5" x 3.4").

modifications reserved

1. Assembly (Skipping this can lead to troubles !)

Ok, so we have your attention. These hints will help you to make this project successful. Read them carefully.

1.1 Make sure you have the right tools:

- A good quality soldering iron (25-40W) with a small tip.
- Wipe it often on a wet sponge or cloth, to keep it clean; then apply solder to the tip, to give it a wet look. This is called 'thinning' and will protect the tip, and enables you to make good connections. When solder rolls off the tip, it needs cleaning.
- Thin raisin-core solder. Do not use any flux or grease.
- A diagonal cutter to trim excess wires. To avoid injury when cutting excess leads, hold the lead so they cannot fly towards the eyes.
- Needle nose pliers, for bending leads, or to hold components in place.
- Small blade and Phillips screwdrivers. A basic range is fine.

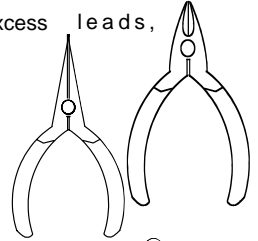
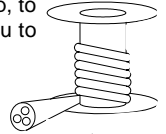
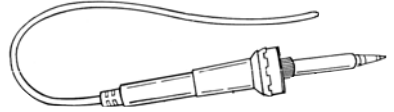

leads,



For some projects, a basic multi-meter is required, or might be handy

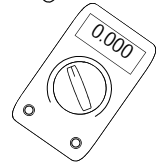

1.2 Assembly Hints :

- ⇒ Make sure the skill level matches your experience, to avoid disappointments.
- ⇒ Follow the instructions carefully. Read and understand the entire step before you perform each operation.
- ⇒ Perform the assembly in the correct order as stated in this manual
- ⇒ Position all parts on the PCB (Printed Circuit Board) as shown on the drawings.
- ⇒ Values on the circuit diagram are subject to changes.
- ⇒ Values in this assembly guide are correct*
- ⇒ Use the check-boxes to mark your progress.
- ⇒ Please read the included information on safety and customer service
- ⇒ * Typographical inaccuracies excluded. Always look for possible last minute manual updates, indicated as 'NOTE' on a separate leaflet.

1.3 Soldering Hints :

1- Mount the component against the PCB surface and carefully solder the leads

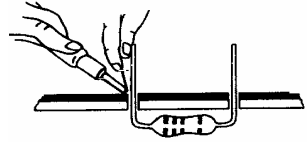

2- Make sure the solder joints are cone-shaped and shiny

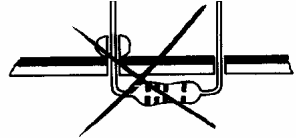
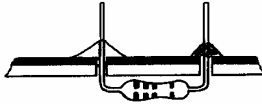

3- Trim excess leads as close as possible to the solder joint

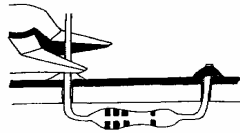

REMOVE THEM FROM THE TAPE ONE AT A TIME !

AXIAL COMPONENTS ARE TAPED IN THE CORRECT MOUNTING SEQUENCE !

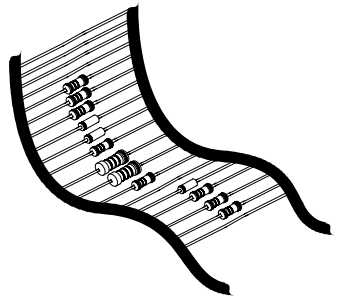

1. Jumpers

□ J : 8X

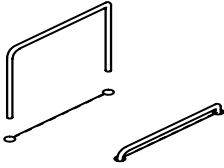

Choice between different input sensitivities :

- Mount the jumpers JH for a sensitivity of **950mV**.
- Mount the jumpers JM for a sensitivity of **500mV**.
- Leave both jumper connections **OPEN** for a sensitivity of **150mV**.

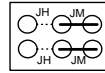
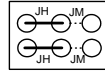

☞ A bipolar **THREE POSITION** switch may be mounted here as well!

Choice between stereo or mono :

- Mount the jumpers JS for a **stereo amplifier**.
- Mount the jumpers JB for a **mono-bridged amplifier**.

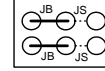
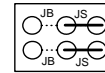

☞ Here a **unipolar** change-over switch may be mounted as well!

2. Diodes. Watch the polarity!

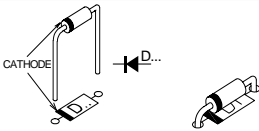

- D1 : 1N5404
- D2 : 1N5404

3. Zener diodes. Watch the polarity!

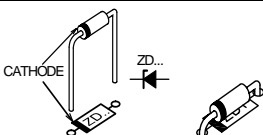

- ZD1 : 15V0
- ZD2 : 15V0

4. 1/4W Resistors

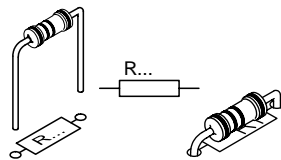

- R1 : 22K (2 - 2 - 3 - B)
- R2 : 22K (2 - 2 - 3 - B)
- R3 : 22K (2 - 2 - 3 - B)
- R4 : 22K (2 - 2 - 3 - B)
- R5 : 22K (2 - 2 - 3 - B)
- R6 : 22K (2 - 2 - 3 - B)
- R7 : 22K (2 - 2 - 3 - B)
- R8 : 2K2 (2 - 2 - 2 - B)
- R9 : 1K8 (1 - 8 - 2 - B)
- R12 : 47K (4 - 7 - 3 - B)
- R13 : 120K (1 - 2 - 4 - B)

- R14 : 68K (6-8-3-B)
- R15 : 220K (2-2-4-B)
- R16 : 1K5 (1-5-2-B)
- R17 : 1K5 (1-5-2-B)
- R18 : 560 (5-6-1-B)
- R19 : 560 (5-6-1-B)
- R20 : 2K7 (2-7-2-B)
- R21 : 2K7 (2-7-2-B)
- R22 : 100K (1-0-4-B)
- R23 : 470K (4-7-4-B)
- R24 : 10K (1-0-3-B)
- R25 : 33 (3-3-0-B)
- R26 : 33 (3-3-0-B)
- R27 : 33 (3-3-0-B)
- R28 : 33 (3-3-0-B)
- R29 : 390 (3-9-1-B)
- R30 : 390 (3-9-1-B)
- R31 : 390 (3-9-1-B)
- R32 : 390 (3-9-1-B)

5. Metal film resistors

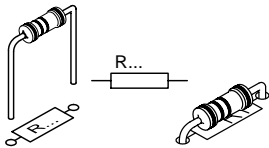

- R10 : 7K5 (7-5-0-1-1)
- R11 : 20K (2-0-0-2-1)

6. 1W resistors.

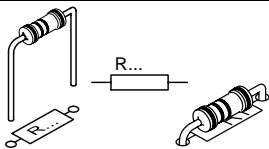

- R33 : 1K (1-0-2-B)
- R34 : 1K (1-0-2-B)
- R35 : 1K (1-0-2-B)
- R36 : 1K (1-0-2-B)

7. 5W resistors.

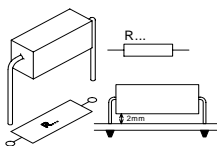

- R37 : 0,1
- R38 : 0,1
- R39 : 0,1
- R40 : 0,1

8. IC sockets.

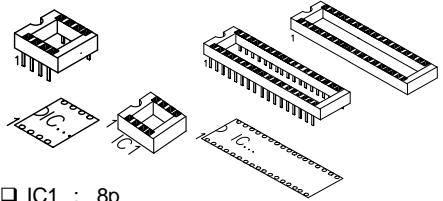

- IC1 : 8p
- IC2 : 20p

9. Ceramic Capacitors

- C1 : 15pF
- C2 : 15pF
- C3 : 100pF (101)
- C4 : 100pF (101)
- C5 : 100pF (101)
- C6 : 100pF (101)
- C7 : 100pF (101)
- C8 : 100pF (101)
- C9 : 150pF (151)
- C10 : 150pF (151)
- C11 : 150pF (151)
- C12 : 150pF (151)
- C13 : 1n2 (122)
- C14 : 1n2 (122)
- C15 : 100nF (104, μ 1)
- C16 : 100nF (104, μ 1)
- C17 : 100nF (104, μ 1)
- C18 : 100nF (104, μ 1)

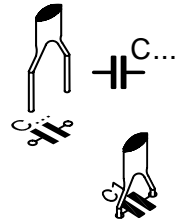

10. PCB tabs.

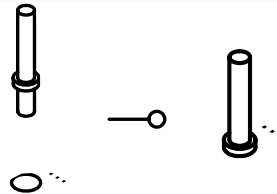

- T1 : E, B & C
- T2 : E, B & C
- T3 : E, B & C
- T4 : E, B & C

TS : if a thermal protection is to be connected.

11. Fuse holders + Fuses

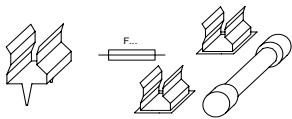

- F1 : 6,3A "slow"
- F2 : 6,3A "slow"

12. Capacitors

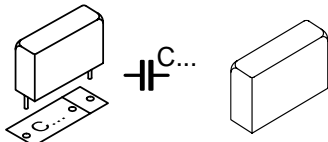

- C21 : 1 μ F/63V
- C22 : 1 μ F/63V

13. Spade connectors

- LS
- +LS
- GND : 3x
- +V
- V

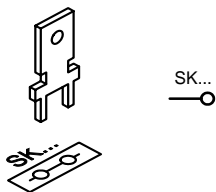

14. Electrolytic capacitors. Check the polarity!

- C19 : 0,47 μ F
- C20 : 0,47 μ F
- C23 : 2 μ 2
- C24 : 4 μ 7
- C25 : 4 μ 7
- C26 : 22 μ F
- C27 : 22 μ F
- C28 : 100 μ F
- C29 : 100 μ F
- C30 : 100 μ F
- C31 : 100 μ F
- C32 : 220 μ F
- C33 : 220 μ F
- C34 : 220 μ F
- C35 : 220 μ F
- C36 : 4 μ 7

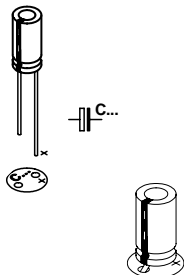

15. Led's. Watch the polarity!

- LD1 : 5mm red.
- LD2 : 5mm red.

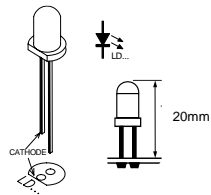

16. Cinch connector(s)

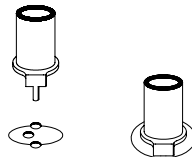

For stereo use :

- Left input
- Right bridge input

For mono-bridged use :

- Right bridge input

17. IC's. Watch the position of the notch!

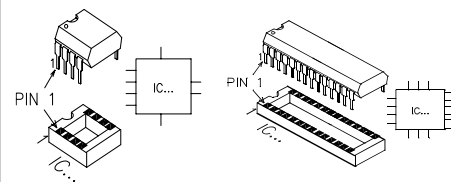

- IC1 : TL072
- IC2 : TDA7250

👉 Resistors R41 & R42 and capacitors C37 & C38 are not being used!!!

18. Mount the PCB in the heat sink

- ❑ Slide the PCB in the largest slot of the heat sink. (See fig. 1.0)

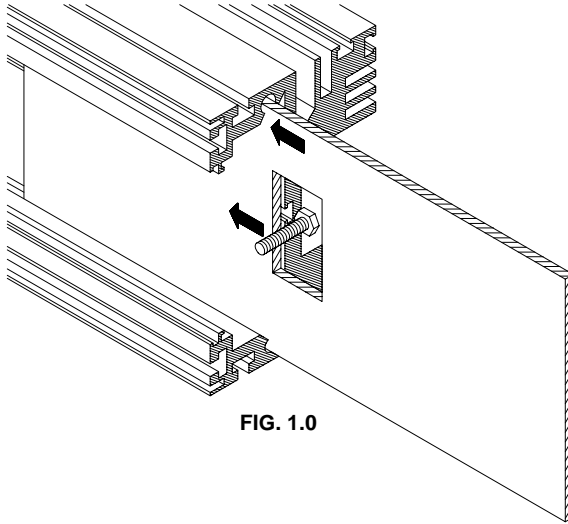

FIG. 1.0

- ☞ **Note** : If the optional thermal protection is used, a hexagonal bolt should be slit into the mounting slot, and into the hole in the P.C.B. Then the THERMIC may be mounted on the heat sink and its terminals may be connected to the positions TS (see Fig. 2.0).

- ❑ Position the P.C.B. in the middle of the heat sink.

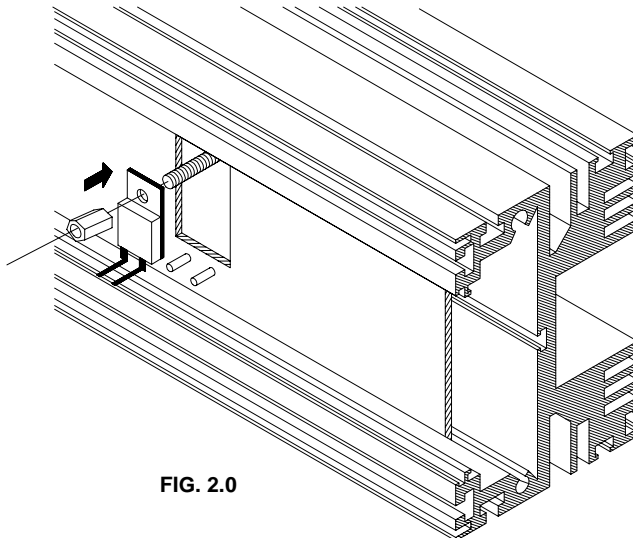

FIG. 2.0

19. Power transistors

Two transistors are mounted at both ends of the heat sink (for their positions refer to Fig. 3.0).

- T1 & T2 : TIP142 of motorola!
- T3 & T4 : TIP147 of motorola!

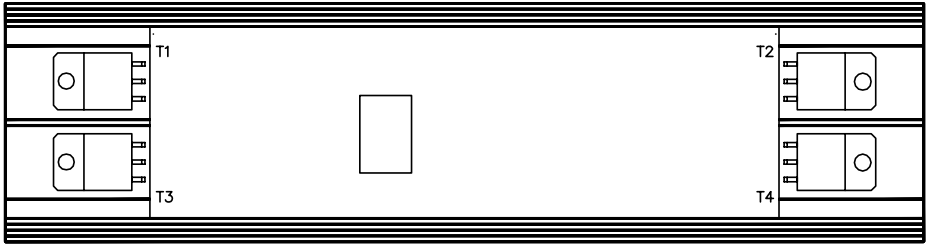
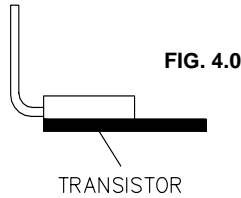

FIG. 3.0

- Bend the connections of each transistor as in Fig. 4.0.



- Put them in the correct position on the heat sink and against the P.C.B., mark the place of the transistors.
- Apply a drop of thermally conductive paste to the points where the transistors will be mounted (Fig 5.0).

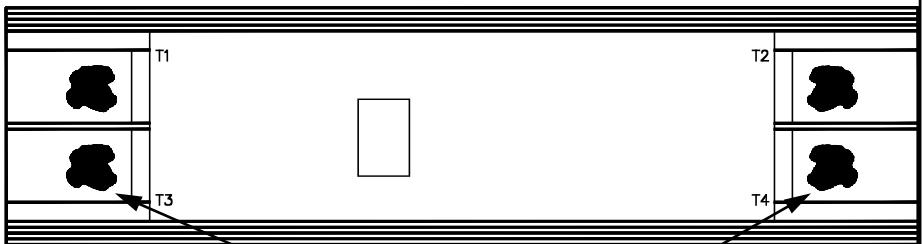
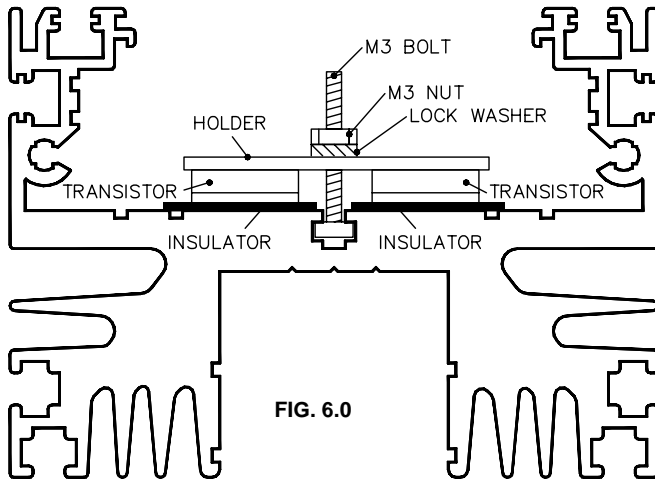

FIG. 5.0

thermally conductive paste

- Put an insulating mica on the drop of paste.

- ❑ Apply a drop of paste on each transistor and put them in the correct position on the heat sink and against the P.C.B. Make sure the correct type of transistor is placed in the correct position (T1...T4).
- ❑ Fix the transistors well in place by means of the supplied plate and a hexagonal bolt, which is slit into the slot in the heat sink (see Fig. 6.0). Make sure the transistor connections do **NOT TOUCH** the metal plate!



- ❑ Now the transistors may be soldered to the corresponding print pins.

20. Test

- ❑ Connect a symmetrical power supply unit (possibly the APS200, SPS200 or K3508 module) of + and - 30 tot 45VDC to the positions GND (0V), -V and +V. See Fig. 7.0.

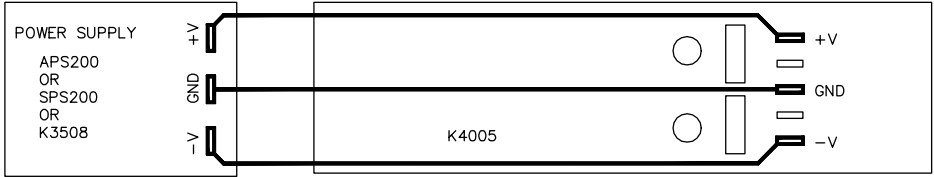

FIG. 7.0

IMPORTANT: Do not switch on the supply voltage before the connections to the amplifier are made!

- ❑ Switch on the supply voltage. Normally both LEDs on the amplifier P.C.B. should light up to indicate that the power supply is alright.

Carry out the following measurements:

- Across each of the 5W resistors R37 to R40 a voltage of about 0.01V should be measured.
- Between each speaker output terminal and the GND terminal a voltage of about 0V (max. 0.5V) should be measured.

The amplifier is now ready for use.

21. Use and connection

NOTE : Carry out all connections by means of 1.5mm wire and the supplied flat connector bushes. Solder the wire to the connector bushes and slide the insulation over them.

1. As a stereo amplifier:

- See Fig. 8.0 for the connection of the power supply and the speakers.
- Watch the polarity of the speakers!

FIG. 8.0

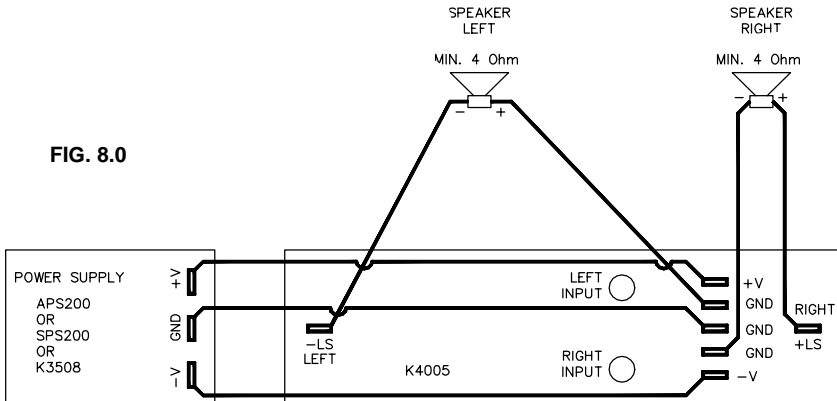

2. As a mono-bridged amplifier:

- See Fig. 9.0 for the connection of the power supply and the speaker.
- Make sure that the impedance of the connected speaker is not less than 8 ohms.

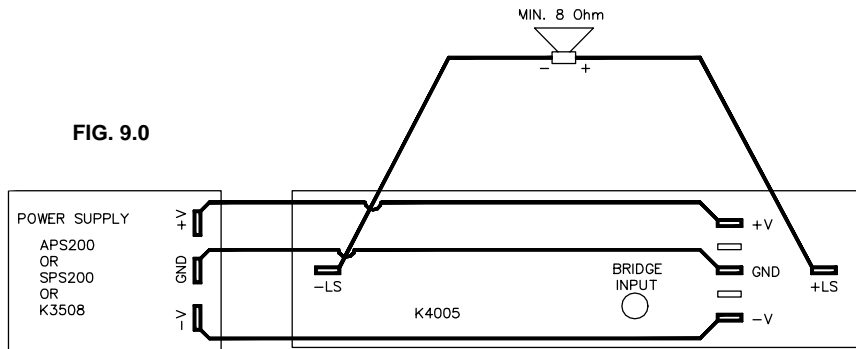

IMPORTANT: Always connect the outputs first, before the power supply is switched on.

If the amplifier is to be used as a free-standing unit, it may be attached by means of M4 hexagonal bolts and the corresponding slots in the heat sink.

Always mount a 10 ohm (1/4W) resistor in series with the piezo tweeter, both for stereo and for mono amplification

22. Diagram power supply

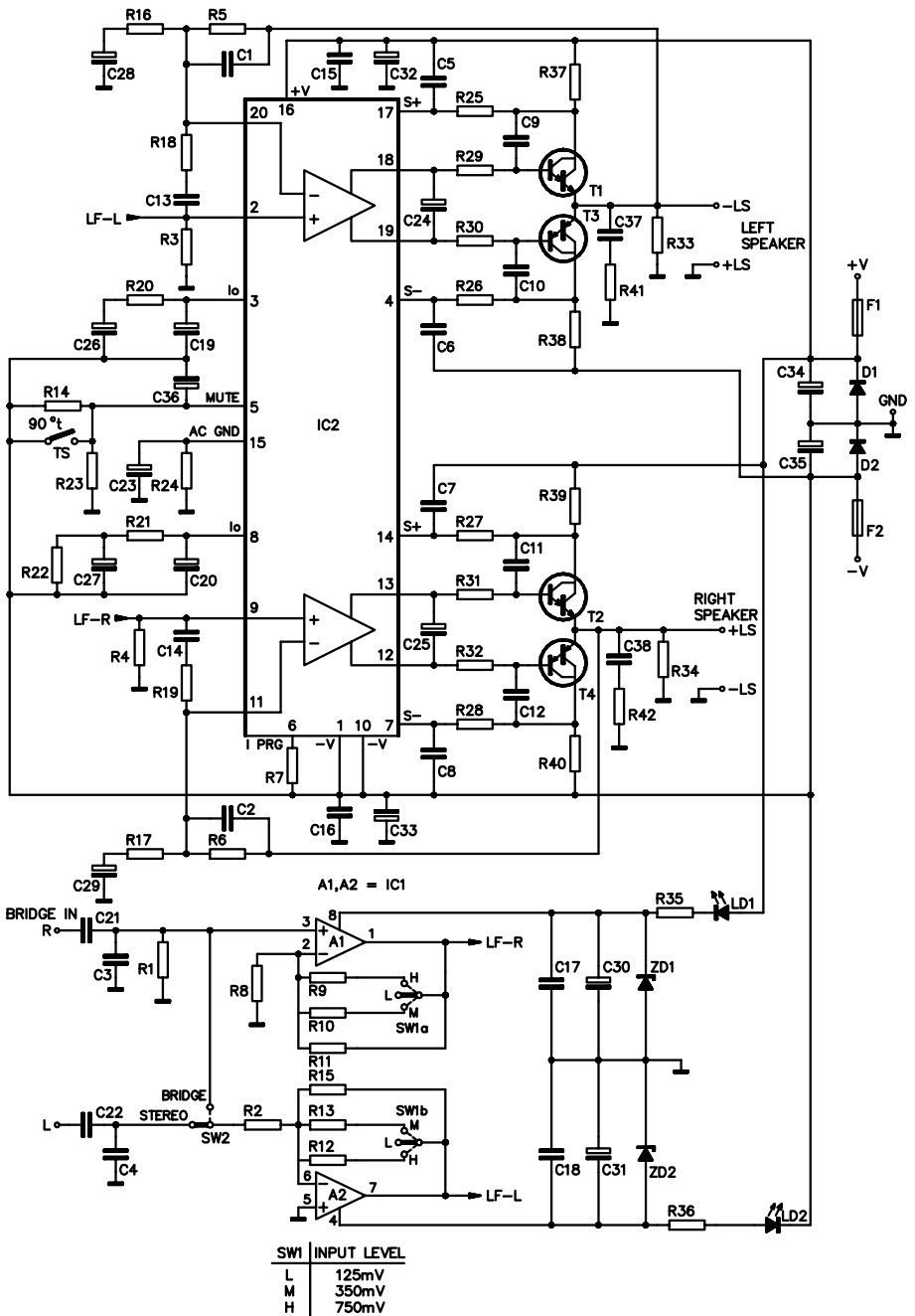

23. PCB

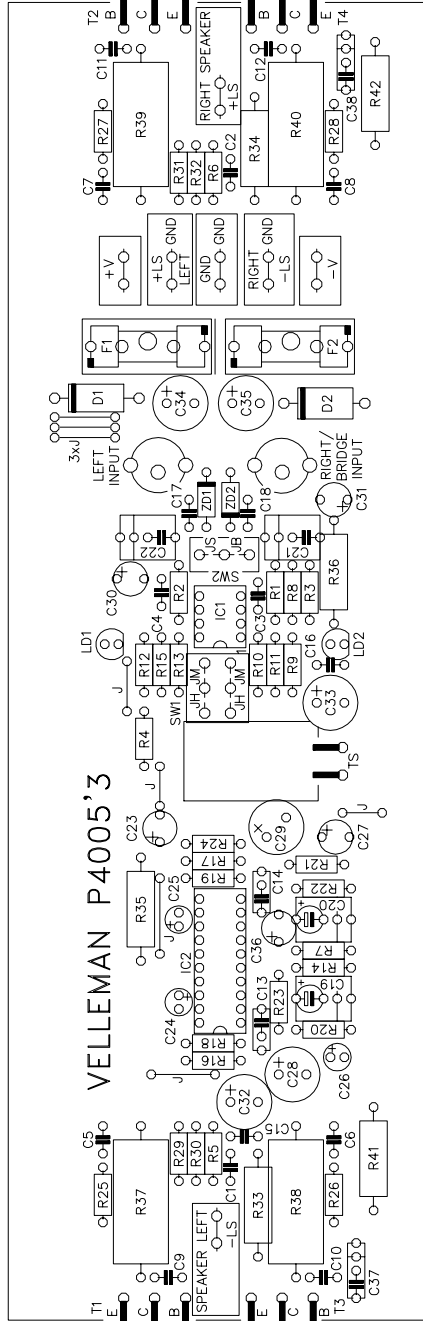



VELLEMAN KIT NV
Legen Heirweg 33
9890 Gavere
Belgium Europe
Info ? : <http://www.velleman.be>

Modifications and typographical errors reserved
© Velleman Kit nv
H4005B_IP - 2004 - ED2 (rev1)

